



StreetJet

1-2-3 GO!



QUICK TO CONNECT. EASY TO USE. POWERFUL TO DRIVE.

QUICK TO CONNECT

- The patented One Touch clamps enable easy, fast and effortless docking to the wheelchair for pure driving fun.

EASY TO USE

- The StreetJet was designed with people with limited hand function in mind. All functions can be performed with little force.

POWERFUL TO DRIVE

- High performance motor and high battery capacity deliver up to 50 km long rides, even on rough surfaces, for worry-free driving fun.

HIGHLY PERSONALISABLE

- The StreetJet offers a broad range of accessories and colour options, plus an individual adjustable acceleration to make it the perfect fit to you.



MORE POWER FOR EXTENDED TOURS

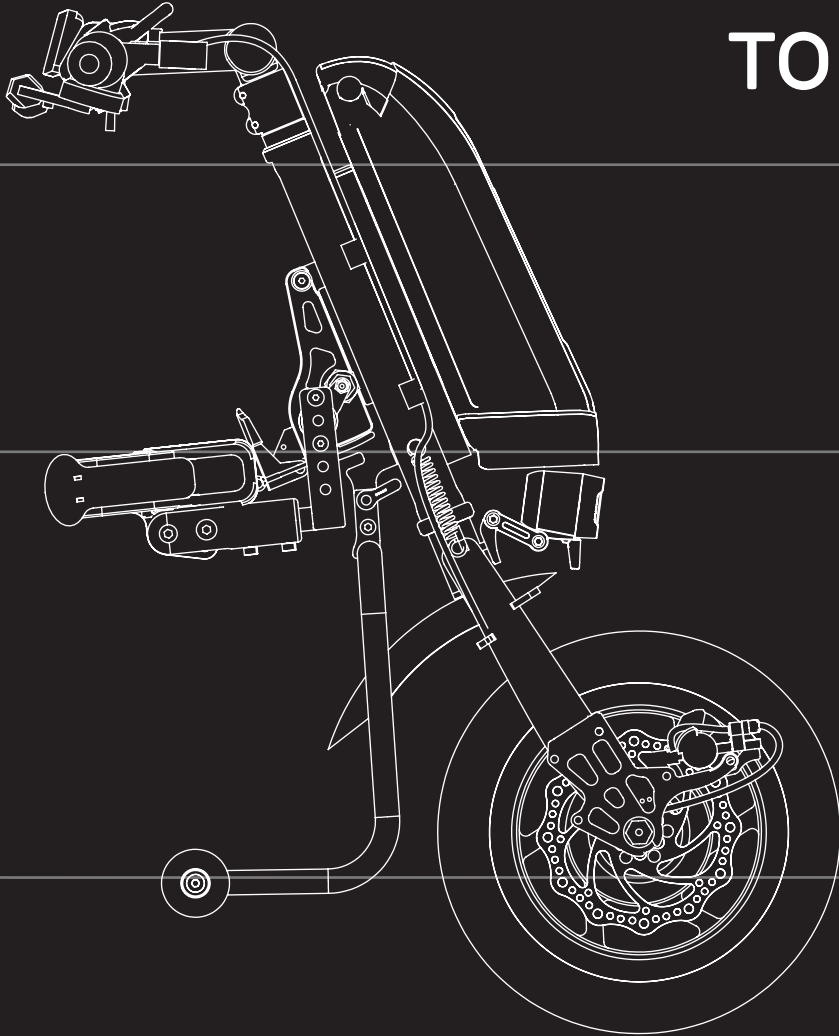

The Empulse StreetJet is a reliable and "zero emission" solution for those who prefer a sporty, long distance ride and want the ability to tackle difficult terrain.

Thanks to StreetJet's power you can satisfy your longing for adventure and experience a new sense of freedom and independence. Take advantage of the extra power the motor provides to go the long distances and don't let tired shoulders dictate where you go. Available in 630 Watt (12") or 750 Watt (16").

The fine-tuned, high performing electrical system consisting of an efficient high torque brushless motor and a high-capacity Lithium-ion battery provides power for effortlessly tackling slopes and extended tours.

Cruise control and a pneumatic tire guarantee comfortable riding even on long rides.

Almost everyone can enjoy unlimited mobility - young or old, for urban or rural use. The StreetJet provides loads of fun and an unadulterated riding experience - around town or along country roads.

ONE TOUCH CLAMP SYSTEM

PATENTED

The patented One Touch Clamps were developed to enable **easy, fast and effortless docking** to the wheelchair.

The design of the clamps allows to simply attach only by a little "push" **even for people with limited hand function**.

The One Touch Clamps have been designed to fit a wide range of frame shape and **do not require any additional accessories on your wheelchair**, which would interfere and add weight when not in use.

No need to lift the StreetJet due to the stand with wheels, clamping design and reverse gear.

The StreetJet is always ready when you are.



1 Open the One Touch Clamps, drive with the wheelchair front frame into the One Touch Clamps, close them by a simple push



2 Pull and hold the docking release lever on the handlebar, in parallel, push the handlebar forwards/upwards or use the reverse gear, and release docking release lever



3 Close the little red lever on the central section and enjoy pure driving pleasure!

GO!



CHOOSE YOUR WHEELSIZE

12" WHEEL

For shorter base length and smaller turning circle - your choice for urban environments and for transportation.



16" WHEEL

For increased comfort and to tackle difficult terrain - your choice for your outdoor adventures.



MADE TO BE TAKEN OFF THE BEATEN PATH

Enhance your mobility – whether it is commuting to work, exploring the city or outdoor adventures, the power support of the StreetJet will enhance the comfort of your mobility and allow you to feel the freedom whilst exploring new paths and extending your personal range. The LED lights ensure greater visibility during foggy days and dark nights.



KEEP EVERYTHING UNDER CONTROL

1 Angle adjustable handlebar

2 Throttle lever for ergonomic and precise operation

3 Proportional electrical motor brake lever for fine dosed deceleration

4 Docking release lever ensures safe and easy docking and undocking the StreetJet with both hands on the handlebar

5 Mechanical brake lever to operate the Disc braking system. The parking brake lever allows to park your wheelchair on unflat surfaces.

6 Cruise control maintains the speed and lets you enjoy driving around at the same speed for a long period of time

7 Forward and reverse control for easy manoeuvring forwards and backwards

8 Easy to read, LCD display to monitor speed, total distance, trip distance, battery-condition and powerconsumption



Set up the speed-mode, or adjust independently the acceleration (e.g. slower acceleration for people with less trunk stability)

MORE DISTANCE FOR MORE ADVENTURES

The Lithium-ion 14Ah battery with Intelligent Battery Management System, enables you to take rides up to 50 km. This means long trips without worrying about charging the battery, allowing you to just enjoy the ride. The USB charging port enables you to charge your phone. No worries your phone battery is depleting while using a navigation app or listening to music.



BRAKING POWER YOU CAN RELY ON

The precise and **powerful disc brake**, with an efficient power transmission and fast responding braking force, provide the right deceleration, even on different surfaces and weather conditions.

Twin or optional triple brake system for comfort and increased safety. The twin brake system includes a mechanical disc brake and separate proportional electric brake. The optional triple brake system has a dual mechanical brake and separate electric brake.



FORK AND MAIN FRAME COLOURS: POWDER COATED

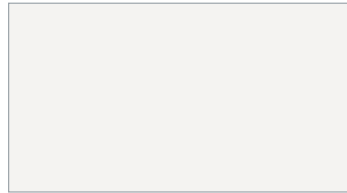

White gloss 100

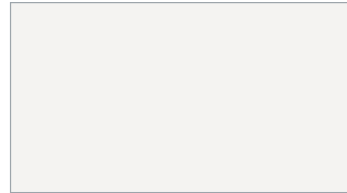

White matt 101



Black gloss 103



Black matt 105



Green gloss 107



Red gloss 108



Yellow gloss 120



Grey matt 131



Grey gloss 132



Light grey matt 133

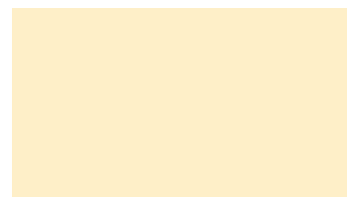

Cream gloss 135



Duckegg blue gloss 141



Forest green gloss 143



Navy blue matt 152



Purple gloss 157



Dark blue gloss 151



Royal blue gloss 154



Blue gloss 174



Orange gloss 180



Pink gloss 188

Anodised Colour Kit

(stand, central section, One Touch Clamps) 5 colours colors available:



Anodised,
black



Anodised,
red



Anodised,
blue



Anodised,
purple



Anodised,
gold

Cable colour

(brake cable, docking release cable) 3 colours available:



Black



Blue



Red

The StreetJet has numerous accessories available for your personal needs. These accessories are designed specifically for the StreetJet for the perfect compatibility.

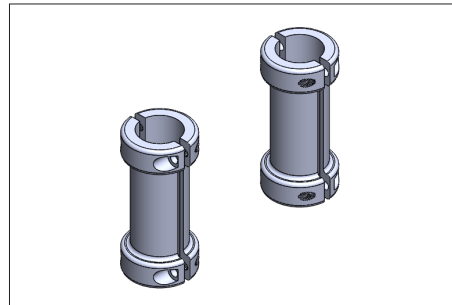

Front Frame Protector

Available for round and oval tubes, protects your wheelchair front frame



Stand with wheels

No need for uncomfortable lifting as the StreetJet will remain in an upright position



LED light

The LED light lightens your way and makes you more visible



Carbon fender

Modern appearance and lightweight



Luggage rack

Sturdy construction that can hold loads up to 8 kg, so you can store and transport your luggage comfortably



Triple-brake, system

Dual mechanical brake, and separate electric brake

Empulse *StreetJet*

TECHNICAL DATA

Operating Voltage	36 Volt
Range of action	up to 50 km (2)
Climbing power	up to 11% (6°)
Motor power (max power)	12" 250 W (630 W) / 16" 250 W (750 W)
Front frame width	220 - 425 mm (1)
Max. user weight	120 kg
Max. speed forward	6 kph; optional 10 or 15 kph (4)
Battery weight	2,6 kg
Total weight w/o battery	from 12,9 kg (3)
Total weight with battery	from 15,5 kg (3)
Battery type	Lithium-ion battery, 36 V 14 Ah, intelligent battery management system
Wheel size	12" pneumatic tyre / 16" pneumatic tyre
Charger	36V, 2A
Brake type	Twin-brake system: mechanical disc brake and separate proportional electric brake. Optional Triple-brake system: dual mechanical brake and separate electric brake



Certified according to all EN12184 applicable standards

- (1) Measured inside tube to inside tube. use only the measured dimension and not the seat width to check compatibility
- (2) According to ISO 7176 - 4, depending on the ground surface, the weight of the user, driving behaviour, temperature and terrain
- (3) Depending on product configuration
- (4) Check your local laws and regulations for max. permitted speed in your country. Speed-settings >6 km/h can only be ordered via Fax with a signed waiver (see Order Form). Max. speed-settings can be altered by Sunrise Medical only



Sunrise Medical GmbH

Kahlbachring 2-4
 69254 Malsch/HD
 Tel.: +49 (0) 72 53 / 9 80-0
 Fax: +49 (0) 72 53 / 9 80-222
 E-Mail: international@sunrisemedical.de
www.SunriseMedical.eu

